

LAGONDA TARAF
“Final Edition”
1 of 4





Lagonda – The Finest of Fast Cars

Since 1906, Lagonda has been the preserve of the few but the subject of desire for the many.

It has always been a marque for those that appreciate something truly exclusive, a luxurious but sporting 4-door 'super saloon' which gives a "Concorde" style of opulence but with a purpose. The pinnacle of engineering clothed in a beautiful form and all built in the most exclusive of numbers globally.

The Lagonda Taraf offers just that, a hand-built car able to deliver you in great comfort and style but with the capability of speed and agility that belies its form. The Lagonda Taraf has a unique character which rewards both the driver as well as the passenger.

We are offering selected customers of Aston Martin Lagonda the rare opportunity to purchase one of an extremely limited run of the last Lagonda Tarafs – the Final Edition. The following pages detail the specification of this unique addition to our range.



The Lagonda Heritage

1906

Founded by Wilbur Gunn.
The company was named after
Lagonda Creek in Springfield, Ohio

1910

The Lagonda Torpedo wins the
famous Moscow to St Petersburg Trail



1925

Lagonda produces its first
luxury sports car, the 1460



1933

Lagonda 16V16 Open Tourer



1934

Produced the
Lagonda Rapier

1936

Lagonda produces the
stunning LG45 drop head



1953

Lagonda produces the 3 Litre
Sports Saloon

1961

Lagonda unveils the Aston Martin
Lagonda Rapide, based on a DB4



1993

Lagonda Vignale concept car
shown at Geneva Motor Show

1907

Lagonda commences production of
motorbikes, soon to be followed by
their first car known as Tricar



1931

Lagonda produces the 2 Litre in
high and low chassis variants



1935

John Hindmarsh and Luis Fontes win
Le Mans for Lagonda with the M45 Rapide

1936

Lagonda produces the
LG45 Rapide



1947

1939

Lagonda sold to
Aston Martin

Lagonda scores a 3rd and
4th place in class at Le Mans in a
V12 known as "the old number 5"



1976

Lagonda launches the futuristic design of
Aston Martin Lagonda by William Towns



2009

Aston Martin launch Lagonda SUV
Concept at Geneva Motor Show



The Golden Age of Travel

The Final Edition Taraf features an elegant specification incorporating a theme which evokes the standard colours offered by Lagonda motorcars in the height of the Art Deco Period.

The Ultramarine Black exterior colour harks back to the time when Dark Blue was considered the signature colour for all Lagondas. Meanwhile, the crimson accents also give away an “old Masters trick” of using the smallest red element to draw the eye. In addition, Red was the colour of Le Mans-winning Lagonda M45R in 1935



M45R images kindly supplied by The Louwman Museum, The Netherlands













Standard & Q Equipment - Exterior

The Final Edition Taraf features a number of bespoke items as well as an enhanced list of standard specification that elevate these small number of cars to unprecedented levels and enhance their value even further

- Ultramarine Black Paint
- 10-spoke Silver Diamond Turned Wheels
- Bespoke Solid Sterling Silver Lagonda Wings Badge with red transparent enamel
- Bespoke Volcano Red Side Strake Housing
- Black Bonnet & Side Strake Meshes
- Q fender badges





Standard & Q Equipment - Interior

- Bespoke two-tone trim split:
 - Upper Environment- Aurora Blue
 - Seats and Lower Environment – Q White Essence Semi-aniline
 - Seat Inners – Snowflake Perforation
- Aurora Blue Colour-Keyed Steering Wheel
- Bespoke Red trans-enamel rotaries
- Bespoke Quilt Pattern
- Caspian Blue Carpet with Dark Blue Lambswool Overmats
- Final Edition Sill Plaque
- 3-piece Lagonda Luggage - Aurora Blue leather
- Lagonda Wings embroidery





Technical Specification

Engine, Gearbox and Brakes

- All-alloy, quad overhead camshaft, 48-valve, 5935 cc V12
- Max power 544 PS/537 bhp at 6650 rpm
- Max torque 630 Nm (465 lb ft) at 5500 rpm
- Acceleration 0-60 mph in 4.4 sec; 0-100 km/h in 4.6 sec
- Max speed 314+ km/h (195+ mph)
- Rear mid-mounted, 'Touchtronic III', eight-speed gearbox
- 3-stage Dynamic Stability Control (DSC)

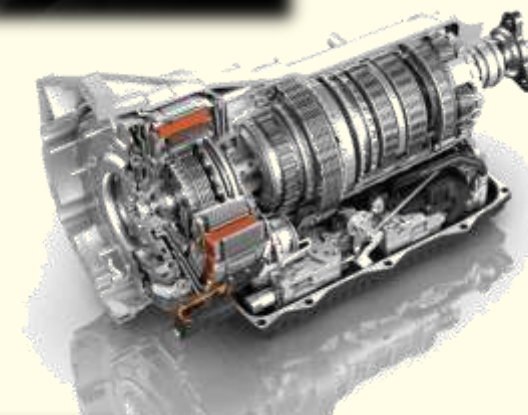



Technical Specification

Suspension, Wheels & Tyres and Brakes

- 3-stage Adaptive Damping System (ADS) with Normal, Sport and Track modes
- 10-spoke Silver Diamond Turned Wheels
- Front Tyres - Bridgestone Potenza 245/40 R20
- Rear Tyres - Bridgestone Potenza 295/35 R20
- Front Dual-cast brake discs, 400 mm diameter with six-piston calipers
- Rear Dual-cast brake discs, 360 mm diameter with four-piston calipers



Dimensions (mm)

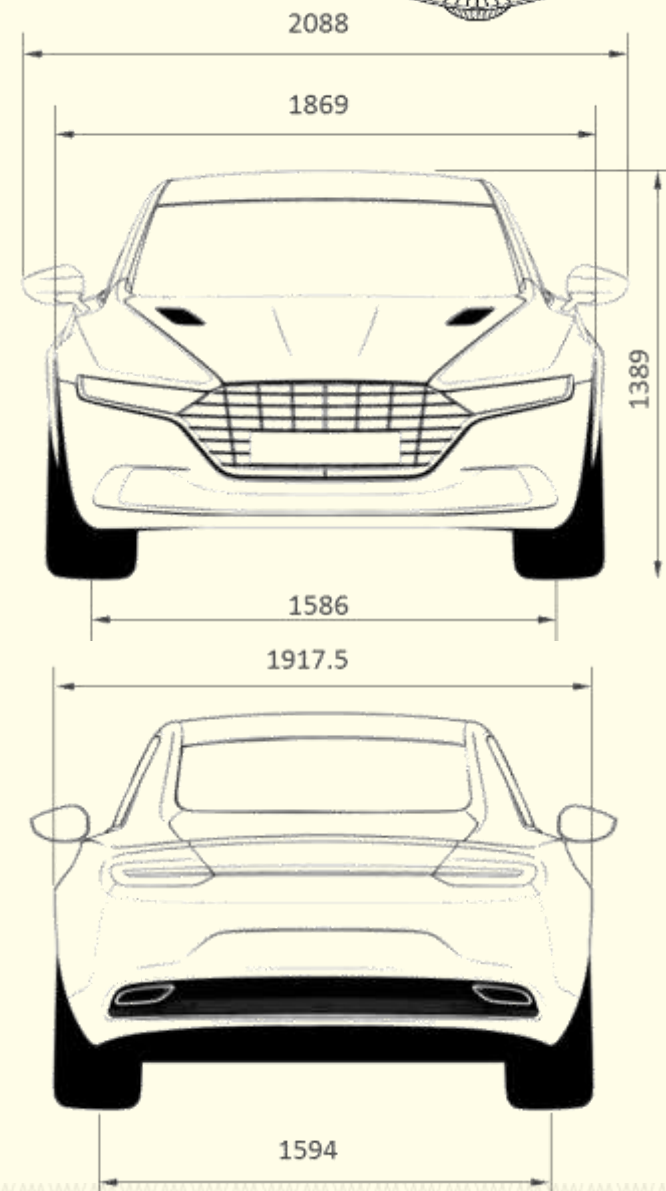
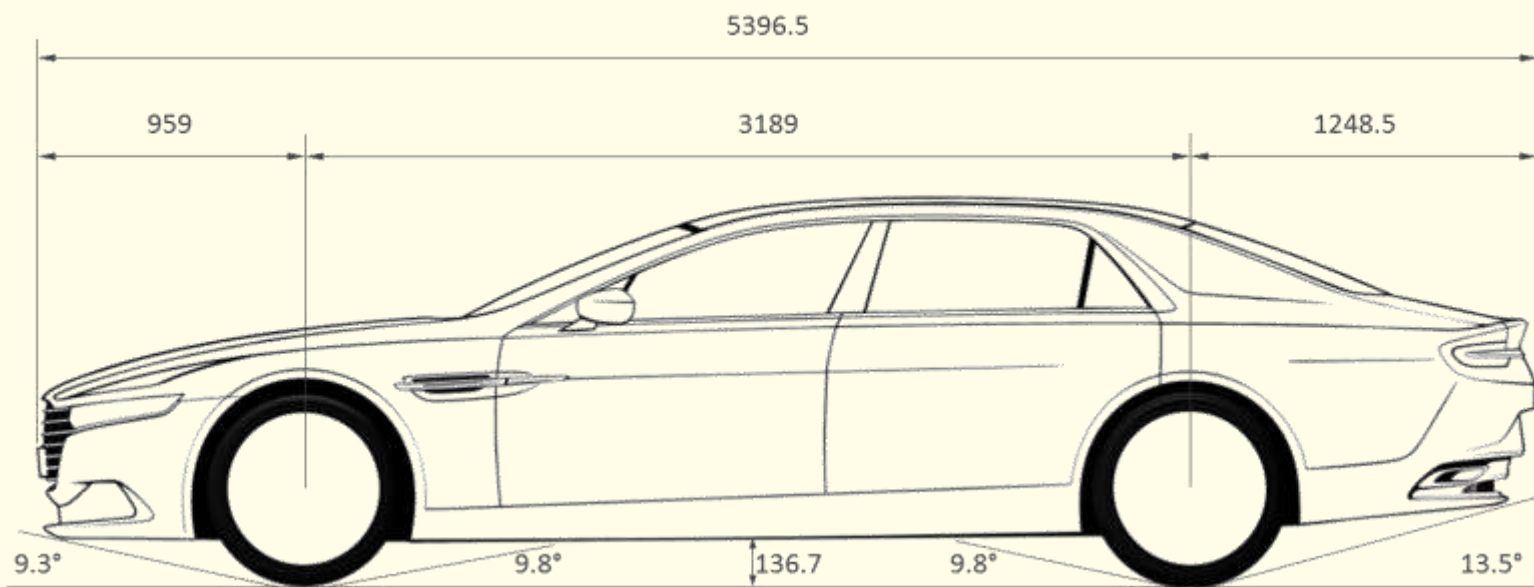



Sales Overview

Name:	Lagonda Final Edition
Volume:	4 units
Deliveries:	From June 2018 (18MY)
Price:	£550,000 ex tax, ex works (Deposit of £250,000 ex tax)
Hand of Drive:	LHD only
Sales Process:	Direct Sales Contract via Aston Martin VIP Sales
Next steps:	Please speak to your Aston Martin Dealer

DISCLAIMER These images are indicative only. Effects such as shading are merely used to indicate certain agreed design features and are illustrative only. Exact colours and/or textures will reflect samples agreed with you in person or by specification form agreed separately (and may differ from the illustration). Whilst we make every effort to ensure the images reflect the original as closely as possible, on screen and printed images may not always perfectly capture original materials and colours. Some items are also subject to change and final design.



Maria Chan

Director – Q & VIP Sales



+44 (0)1926 692398



Maria.Chan@astonmartin.com

Mark Gauntlett

Sales Manager – VIP Sales

+44 (0)1926 644853

Mark.Gauntlett@astonmartin.com

